

(笹本 伸一)
(株)

-
-
- 가 .
- .
- 0.5~1%

가

TSI社가 LaserSpeed System
±0.05%

LDV

가

. 가

가

가

27

/ TSI社

2 가

. LDV

(1).

. 2

2

()

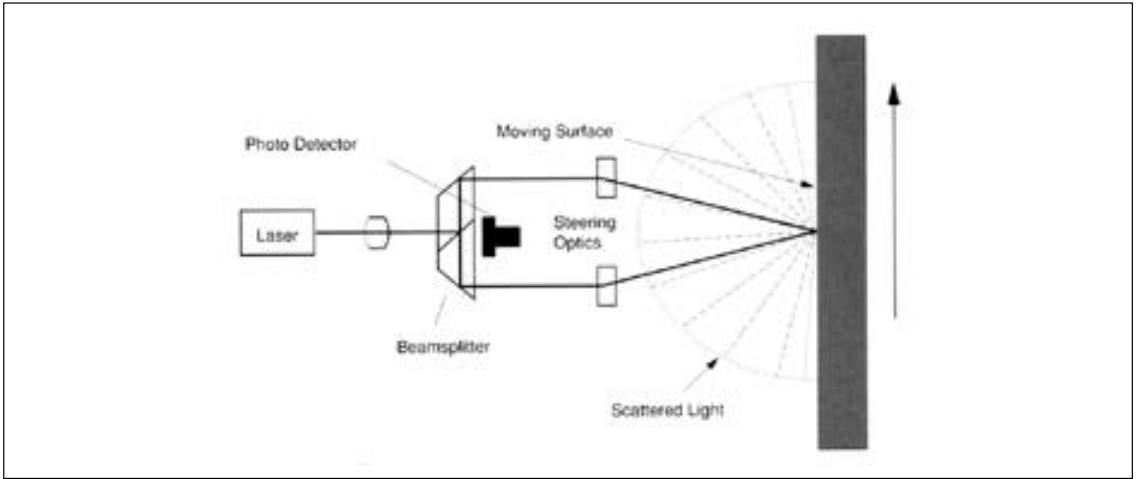

1.

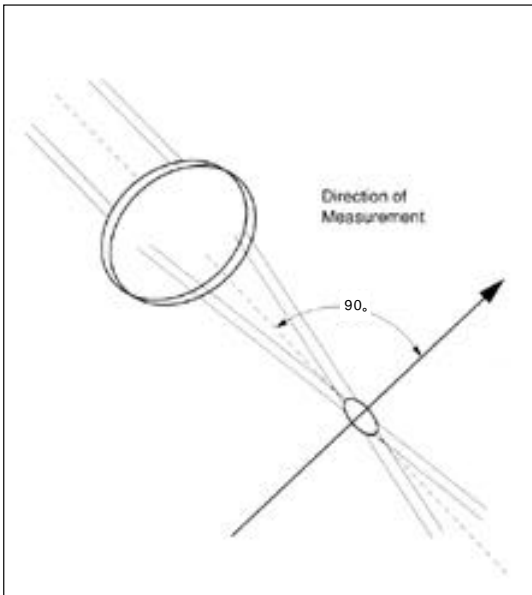

2.

2
 ()
 LDV가 ()
 (2).
 가
 가
 가 2 가 800GHz

가

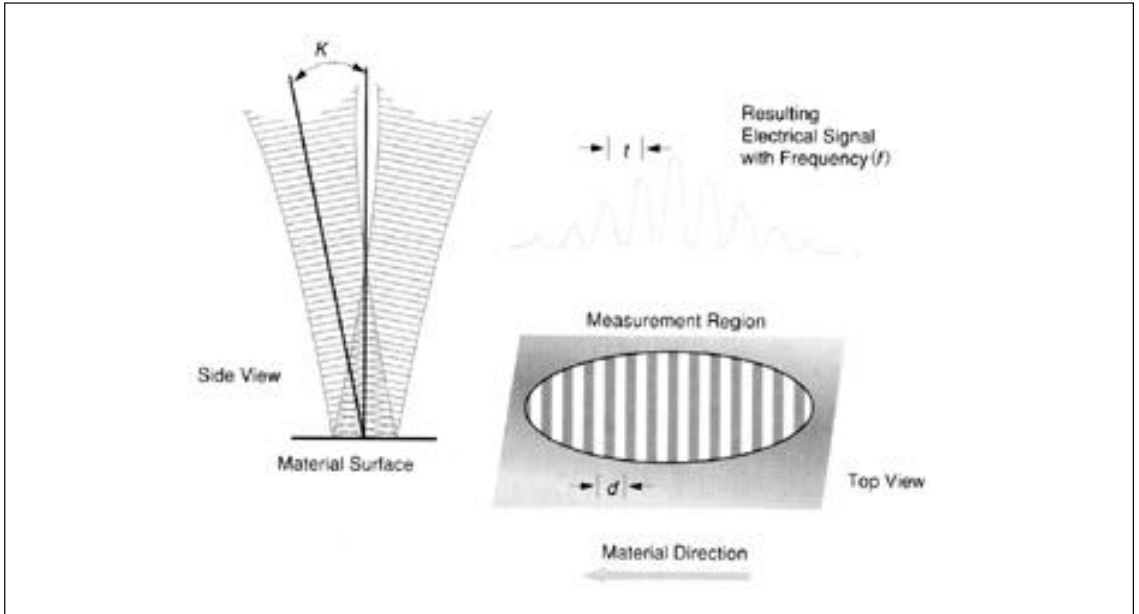

3.

LDV 가

(f) (V) (d)

(2k) ()

(V) = df × f

df = ÷ 2 sin K

(3).

LaserSpeed System

가

2.

LDV

가
가

가 . LaserSpeed System



1.



2.



3.

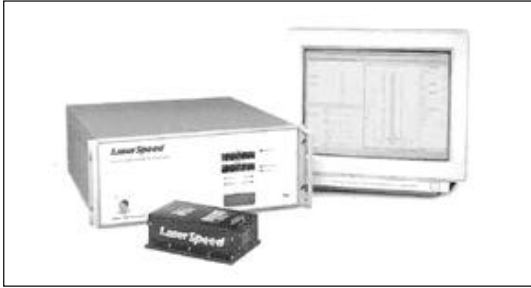

4. QC1100

3. LaserSpeed System
 LaserSpeed System (LS2100)가 ()가
 가 (LS2100) .

4. LDV LaserSpeed System
 (2ms~) 가 가 (1, 2).

5. LaserSpeed System
 PLC 가

가 (RS232C)
 /TSI社 / /

1. (±0.006%) 가 (1 x 10⁶m/s) LS2100 가

AGC 가 , ,

2. LS50PT가 , ,

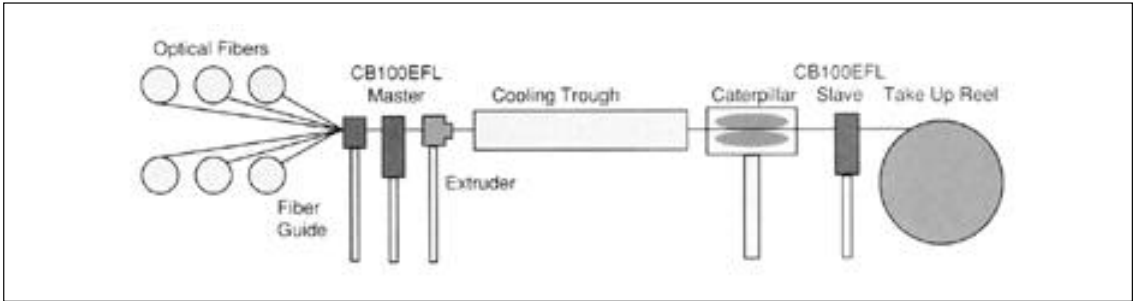

4. EFL

ISO1400

가

가

CB100,

6,000m/

CB150

가

LS50PT

7,200m/

가

EFL

EFL

0.01%(50m

Ø20µm

가

(3).

)

가

(4).

3.

ISO9000

100%

가가

(

가 QC1100 가

),

가



(4).

< > TEL : 81 - 6 - 6877 - 0446

4.

가



게재된 기사는 본지의 웹사이트를 통해서도 보실 수 있습니다.
<http://www.chomdan.co.kr>